



AC POWER SUPPLY

EPO2000S / EPO2000X

INSTRUCTION MANUAL

2-STATION ● EPO

Notice to the customers

Thank you for purchasing the high-efficiency system power supply P-STATION/EPO series.

There are two pages to be corrected in the instruction manual attached to the product. Instruction Manual for High-efficiency System Power Supply EPO 2000S/EPO 2000X (our document No. D:509763).

Please take the trouble to replace the corresponding pages with the following pages in this material:

Page 5-3

Page 12-2

Using the measurement functions

- 1 Every press on  changes the indication of measurement in turn.

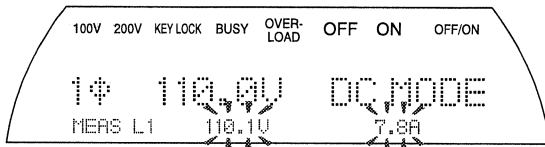

Measurements are shown in the bottom line of the display.

* Measurements of "Voltage", "Current" and "Power" are displayed when in DC output mode.

[Example] Mean value of voltage and current

MEAS L1 110.1V 7.8A

Effective power



MEAS L1 0.86kW



Attention!

- The measurement range is switched automatically.
- The measurement range cannot be fixed.



Attention!

- Mean values are displayed for voltage and current in DC output mode, and AC components are not measured.



Memo

- If the current contains an AC component, a peak value will be detected and this switches the DC measurement range to a higher range.

Attention!

- Load connecting method in DC mode

For fault prevention and safety, if a capacitor, motor or an inductor is used as a load, connect a protective diode (with the maximum inverse voltage of 600 V at least) between the load and the P-STATION/EPO output. Select a large one with the forward current of which the rating is 1.5 times or more of the applied system maximum current.

- If a capacitor (of 150 μ F at least) or a motor is used as a load, connect a blocking diode which prevents the backflow of the current.
- If an inductor is used as a load, connect a freewheel diode so that the counter electromotive force generated when the output is off is absorbed.

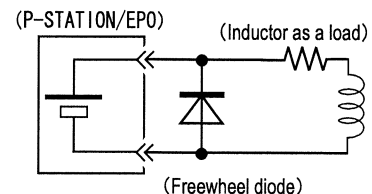
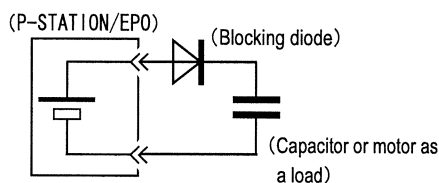

Memo

Most of the switching power units used by connecting with an AC power supply can be operate in DC mode and the measurement of efficiency is sometimes performed with a DC power supply. If this is the case, it is not necessary to connect a protective diode because the backflow from the capacitor, etc. inside the circuit is blocked by the action of the commutating diode (normally of a bridge configuration) located in the input section of the switching power unit.

Rush current versus supply time

* $V_o = 100.0V$ (100V range) or $200.0V$ (200V range), $f = 50Hz$, at Power-ON phase 0°

This indicates the time (rush supply time) spent until the output is restrained by the protective circuit operation when rush current is applied to a resistance load.

Rated current = 20A (100V range), 10A (200V range)

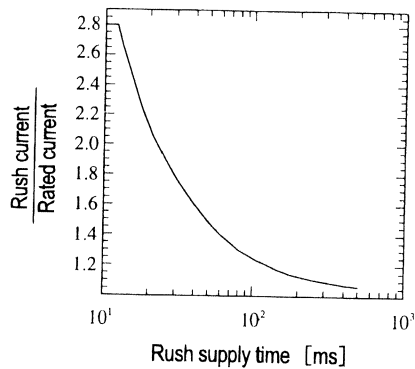
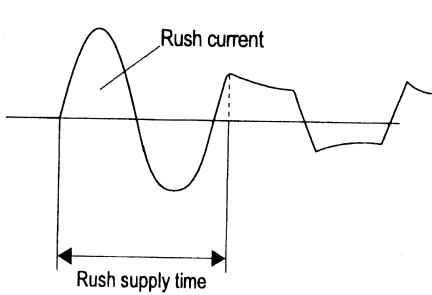

Maximum output current versus frequency

* Maximum current decreases at frequency lower than 40Hz.

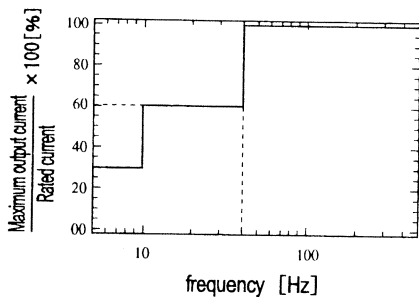

Maximum output current versus output voltage (AC mode)

* Maximum current decreases at voltage higher than 100.0V (for 100V range) or 200.0V (for 200V range).

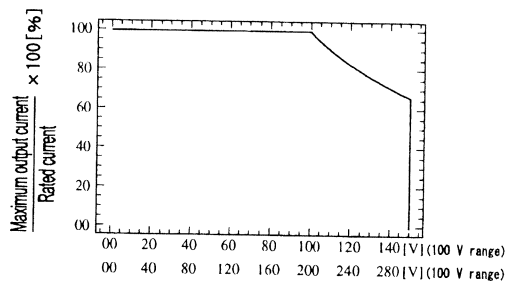

Remarks: [A] means [Arms], [V] means [Vrms] unless any other special description is given. Signal waveform is a sinusoidal wave.

- *1 Setting resolution is 0.1V for phase voltage and 0.2V for line-to-line voltage.
- *2 With sinusoidal wave. Output current decreases if output frequency is 40 Hz or lower.
- *3 With phase current.
- *4 A short period until mean value protection operates. However, repeated application is allowed to capacitor input type rectifying load (at 48 to 62 Hz).
- *5 DC mode cannot be used in single-phase three-wire or three-phase system.
- *6 EPO 2000S and EPO 2000X units are operable at 100V although the output is limited to 800 VA.
- *7 At input voltage of 200V.
- *8 Measurement accuracy is for full scale (FS) of each measurement range.
- *9 Effective measurement range of voltage and current is 40 to 500 Hz.
Effective measurement range of effective power is 45 to 65 Hz.
- *10 Stipulated with chassis - power supply input in package versus output, chassis - output in package versus power supply input.
- *11 Accessories and optional items are excluded.

If the document is incorrectly collated, contact the dealer for replacement.

Notes:

- Copy and reprint of any or all of the contents of this document without permission are prohibited by law.
- Contents of this document are subject to alteration without notification.
- We shall not be responsible for damage resulted from the contents of this document although careful elaboration has been exerted in preparation of the document.
- We shall not be responsible for effects of consequence of operation performed according to the document.

Copyright *NF Corporation 2000*

Caution prior to exportation

- It is prohibited to export or bring out this product from Japan to any foreign country without permission. The predetermined formalities must be done following the applicable laws and rules.

Instructions for safe use of the product

For safe use of EPO 2000S/2000X, observe the instructions in the following section. The company shall not be responsible for, nor take compensation of, the damage resulting from violation of these instructions.

Observe the contents of this document

This instruction manual contains instructions for safe operation and use of EPO 2000S/2000X.

Be sure to read first this manual before starting operation. After thorough reading, store the document carefully so that it will be accessible for reference when uncertainty is encountered in the future.

Observe the descriptions of WARNING and CAUTION

Be sure to observe descriptions of WARNING and CUATION contained in this manual and those affixed on EPO 2000S/2000X units because they are intended to prevent hazard that may result in serious accidents.



This note on the product or in the manual indicates information to avoid hazard which the life or body of the user is subject to during handling of the equipment.



This note on the product or in the manual indicates information to avoid damage to the EPO 2000S/2000X unit.



This symbol on the product indicates controls or functions the use of which requires reference to this instruction manual in advance.

Damage during transport and storage

- If the EPO 2000S/2000X unit is found damaged by vibration or impact during transport or storage, safety protection functions may have been lost. Keep the unit as it is and immediately contact the company or the dealer.

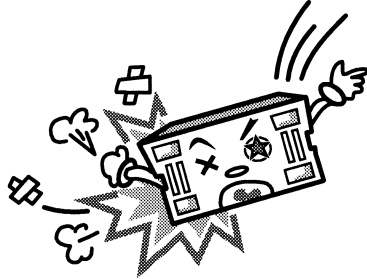

Do not remove the cover or modify the unit

- Never remove the cover. Do not attempt repair, inspection or adjustment of parts inside.
- Never attempt to modify parts inside. This may result in system failure or accidents.

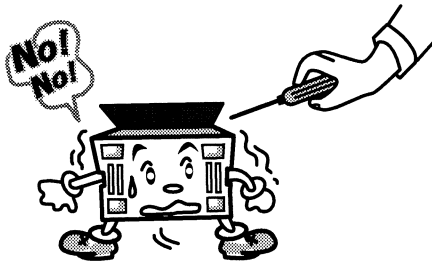

Install the unit in flat and rigid place

- For unit installation, select a flat and strong place free from tilting or vibration that can support easily the weight of the EPO 2000S/2000X unit (approximately 25 kg per unit).

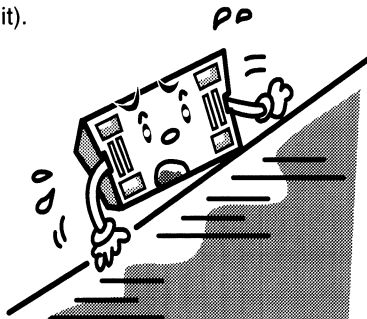

Never select any of the following places for installation

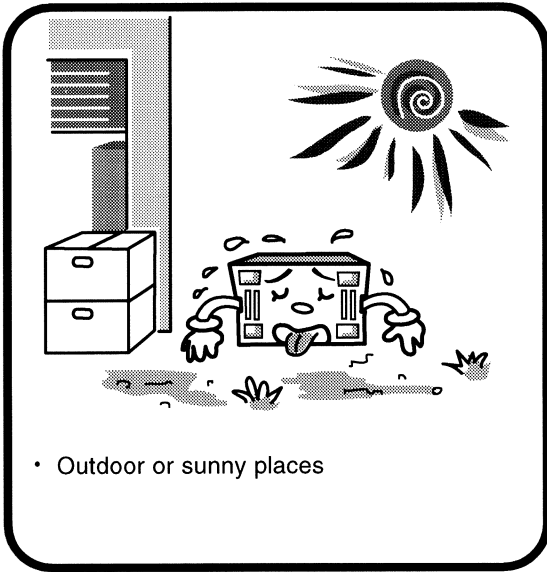

- Outdoor or sunny places



- Small places with poor ventilation

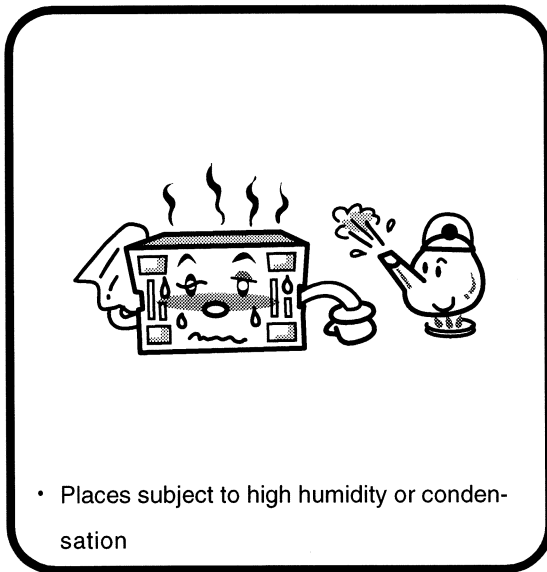

- Places subject to high humidity or condensation



- Dusty and dirty places



- Places exposed to corrosive, explosive or flammable gases



- Places exposed to fire or moisture



WARNING

Power supply cord

- Use the supplied power supply cord for power input. If any other cord is used for unavoidable reasons, select one that has electrical and mechanical properties equivalent to that.

Avoid electric shock

- Be sure to shut off the switch on the power switchboard before connecting the power supply cord.
- Turn off the power switch of the EPO 2000S/EPO 2000X unit before connecting output cables.
- Connect the protective grounding terminal of the EPO 2000S/EPO 2000X unit positively to the electric ground which ground resistance is less than 100 Ω .
- Do not touch by hand the chassis that is not connected to a ground because a line filter is incorporated in the power input section.



- Securely tighten screws and positively plug connectors so that input and output cords and other cables will not be unplugged accidentally. Also pay attention to cord and cable placement to protect them from treading and jerking.

Be alert to burning

- Pay attention to prevent personnel from direct touch on the exhaust port of the EPO 2000S/EPO 2000X unit.



Be aware of electric shock and failure

- If condensation comes into notice, wait until the condensation disappears before connecting the power supply.
- Do not connect other wires other than the grounding wire to the protective grounding terminal.
- Never put foreign matters or liquids in the EPO 2000S/EPO 2000X unit.

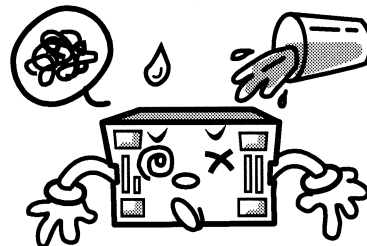

- Wiring in the input and output sections should be carried out elaborately so that the conductive part of the connection cord will not be exposed.



CAUTION

Instructions on use

- Use the product within the specified range of ambient temperature and humidity.

For operation : 0 to 40°C , 10 to 90%RH

For storage : -10 to 50°C, 10 to 90%RH

For guarantee of performance:

5 to 35°C, 50 +10%RH

(No condensation)

- Select a power supply to the EPO 2000S/ EPO 2000X unit in the rated range (single-phase AC power supply of 48 to 62 Hz, 170 to 250 V).

- In order to maintain proper forced air cooling, place the unit so that front and rear sections will be 50 cm or more away from walls for adequate ventilation.

- An EPO 2000S/EPO 2000X unit consumes electric power of about 2800 VA at the maximum. This means, the input current will be approximately 16.5 A if the power supply voltage is 170 V. Therefore, select a power supply with sufficient capacity.

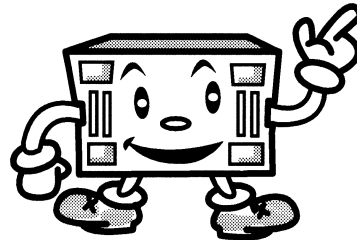



Safety and instructive expressions used in this manual



WARNING

This note on the product or in the manual indicates information to avoid hazard which the life or body of the user is subject to during handling of equipment.



CAUTION

This note on the product or in the manual indicates information to avoid damage to the EPO 2000S/2000X unit.



Attention!

An instruction on operations in which users are likely to do wrong things.



Memo

Introduction of a function useful in some future occasions.

Contents

	PAGE
Instructions for safe use of the product	0-1
Safety and instructive expressions used in this manual	0-6
1. Introduction	
Outline of EPO 2000S/EPO 2000X	1-1
Check accessories in package first!	1-3
2. Name of parts	
Front panel	2-1
Rear panel	2-1
Operation panel	2-2
3. Installation and Connection	
Selection of power supply environment	3-1
Grounding	3-2
Connection to input and output terminals	3-3
Connection to power input terminal	3-3
Connection to output terminal	3-3
Cable connection to screwed terminal block	3-4
Connection of single-phase 2 kVA system	3-6
Connection of single-phase 4 kVA system (use two EPO 2000X units)	3-7
Connection of single-phase 6 kVA system (use three EPO 2000X units)	3-8
Connection of three-phase 6 kVA system (use three EPO 2000X units)	3-9
Connection of single-phase three-wire 4 kVA system (use two EPO 2000X units)	3-10
Prior to starting operation	3-11
4. Fundamental Use - for beginners -	
Turning ON/OFF power supply	4-1
Setting the output voltage range	4-2
Setting the output voltage	4-3
Setting the output frequency	4-4
Turning ON/OFF the output	4-5
Indication of overload	4-6

	PAGE
Using measuring functions	4-7
Setting limits to output	4-8
Setting an upper limit to output voltage	4-9
Setting an upper limit to output frequency	4-9
Setting a lower limit to output frequency	4-10
5. Versatile Use - for advanced users -	
Using the unit as a DC power supply	5-1
Selecting DC output mode	5-1
Setting an output voltage range	5-2
Setting an output voltage	5-2
Using the measurement functions	5-3
Settings for output compensation mode	5-4
Selecting low sensitivity (or high stability)	5-4
Selecting high sensitivity (or precision)	5-5
Using storage function	5-6
Storing settings	5-6
Recalling settings	5-7
Recalling at one action with preset key	5-7
Retrieving on-shipping settings	5-8
Measuring rush current	5-10
Setting the power-on phase on output turn-on	5-10
Using the peak hold function	5-11
6. Use of Enhanced EPO 2000X System	
- increase the system output capacity or use units in a three-phase or single-phase three-wire configuration -	
What functions are available by system enhancement?	6-1
Connection of system cable	6-1
Phase mode	6-1
Restrains on memory	6-1
Using the system as a single-phase 4 or 6 kVA power supply	6-2
Turning ON/OFF the power	6-2
Changing to single-phase mode	6-3
Using the system as a three-phase 6 kVA power supply	6-5
Turning ON/OFF the power	6-5
Changing to three-phase mode	6-6
Exemplary voltage setting: supplying three-phase 200 V output	6-8
Using a measuring function in three-phase configuration	6-9
Different functions in three-phase mode	6-10
Phase indication and phases	6-10

	PAGE
Using the system as a single-phase three-wire 4 kVA power supply ...	6-11
Turning ON/OFF the power	6-11
Changing to single-phase three-wire mode	6-12
Exemplary voltage setting: supplying single-phase three-wire 200 V output	6-14
Using a measuring function in single-phase three-wire configuration	6-15
Different functions in single-phase three-wire mode	6-16
Phase indication and phases	6-16
Reducing the system into a singular unit operation	6-17

7. Useful Functions - versatile functions are ready for use -

Using numeric keypad for setting	7-1
Connecting the numeric keypad	7-1
Selecting operation mode of numeric keypad	7-2
Operation in numeric entry (10KEY) mode	7-3
Setting the output voltage by numeric entry	7-3
Setting memory recall address by numeric entry	7-4
Operation in memory recall (RECALL) mode	7-5
Recalling the contents in memory by a single button touch on the numeric keypad ...	7-5
Line synchronization	7-6
Enabling line synchronization	7-6
Disabling line synchronization	7-6
Setting the reset frequency at the line synchronization OFF moment	7-7
Switching ON/OFF beep warning	7-8
Enabling/disabling beep warning	7-8
Key lock	7-9
Enabling key lock	7-9
Disabling key lock	7-10
Operation with 100 V input	7-11

8. GPIB Interface

Outline of GPIB	8-1
Functions that cannot be operated via GPIB	8-1
Functions that can be controlled via the GPIB but cannot be operated from the panel ...	8-1
Applicable specification	8-1
Connection of GPIB cable	8-2
Instructions on use of GPIB	8-2
Setting for GPIB use	8-3
Selecting the interface	8-3
Setting the GPIB address	8-3
Setting terminator	8-4
Remote status and release from remote condition	8-5

	PAGE
Remote state	8-5
Local state	8-5
Setting the system to "Local lockout"	8-5
Service request and status structure	8-6
Outline of status report	8-6
Status byte	8-6
Sending a service request	8-6
Capture of an event	8-6
Grasp of queue situation	8-6
Status byte register and sending a service request	8-7
Detailed structure of status	8-9
Standard event status register and related registers	8-10
Operation status register and related registers	8-12
Extended event register and related registers	8-13
Warning event register and related registers	8-14
Operation event register and related register	8-15
Fail event register and related registers	8-16
Overload event register and related registers	8-17
Extended status register and related registers	8-18
Program messages	8-19
Program message basic form	8-19
Setting messages	8-20
Data form in setting messages	8-20
Querying message	8-20
Form of response data to a querying message	8-21
Situation in which no message is accepted (Busy)	8-22
Busy related messages	8-22
To recognize BG state from controller	8-22
List of program messages	8-23
Setting of output voltage and output range	8-23
Setting of output frequency	8-24
Switching ON/OFF the output	8-24
Measuring function	8-25
Setting limit values	8-26
Setting a Power-ON phase	8-27
Precision mode and high stability mode setting	8-27
Line synchronization	8-27
AC/DC selection	8-28
Phase mode	8-28
Beep	8-28
Remote sensing AGC	8-29
Monitor output	8-29
Memory	8-30

	PAGE
Hardware structure	8-31
Interface and Status related	8-32
Response to interface message	8-33
Sample GPIB program	8-34
Outline of sample program	8-34
Case where Visual Basic and Kithley's GPIB interface board are used	8-35
Case where Visual Basic and National Instruments' GPIB interface board are used ...	8-39
9. RS-232 Interface	
Outline of RS-232	9-1
Settings for using RS-232	9-2
Selecting the interface	9-2
Setting the transfer rate	9-3
Setting a delimiter for sending	9-3
Setting the parity	9-3
Setting the stop bit	9-4
Setting the character length	9-4
Connection of RS-232 cable	9-6
Handshake	9-7
Sample RS-232 program	9-8
10. Maintenance	
Backup battery	10-1
Calibration	10-1
11. Solution of Trouble	
Fault diagnosis	11-1
Settings retained by backup battery	11-2
Protective functions	11-3
Troubleshooting	11-4
Phenomenon on power turning on	11-4
Buttons are inoperable	11-4
Phenomenon relating to voltage range setting	11-5
Phenomenon relating to frequency setting	11-5
Phenomenon relating to line synchronization	11-5
Phenomenon relating to overload	11-6
Phenomenon relating to measurement function	11-6
Phenomenon relating to storage function and preset	11-6
Phenomenon on power turning off	11-7
If a motor is connected as load	11-7

	PAGE
If a transformer is connected as load	11-8
Frequently asked questions and answers to them	11-9

12. Rating

13. Terminology

Warranty

● CONTENTS ●

Introduction

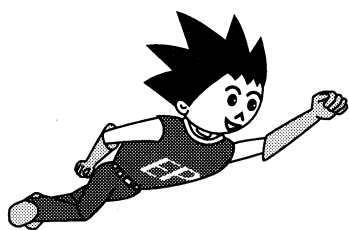



Outline of EPO 2000S/EPO 2000X



Hi, there. My name is "High-efficiency System Power Supply, P-STATION/EPO". Oh, this may be too long for you. Then call me "Epo" in short. Before going to sections of detailed description, I will introduce some of my fortes.

You do simple setting and I will supply high-accuracy voltage.

* Just turn the dial to the desired spot, or use an external numeric keypad (optional) to enter your desired value. This easy setting enables me to provide output voltage of 0 to 300 V in AC or 0 to 424 V in DC with the frequency of 5 to 500 Hz as you desire.

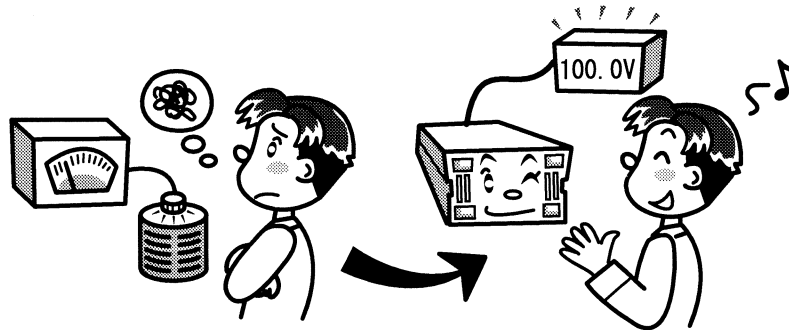

I supply clean and stable voltage.

* Even if the load current fluctuates, I continue to supply a voltage that is mostly constant and free of distortion. Stability of output voltage versus fluctuation to load is 0.1% (typically) or less.

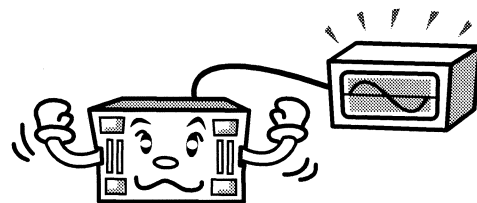

I strive to supply constant output even if the input power fluctuates severely.

* I provide stable output even in an adverse power environment since the range of my tolerance to power supply voltage is so wide (170 V to 250 V) and I have a high tolerance ability against instantaneous power interruptions; namely, the maximum tolerance time is as long as 20ms typically.

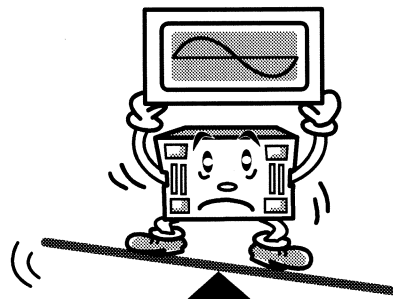

<Higher efficiency and less heating>

The efficiency is improved to the level of about 76% at the maximum. Internal loss at the rated output (2 kVA) is as low as 1/3 of the traditional products (NF's P-STATION/series [Q]), namely, about 600W.

<I am small and light, needing only a limited space.>

I weigh 25kg or so, approximately a half of conventional products. Thanks to the weight reduction, you can easily move me or transport me.

<I am ready to supply rush current.>

I can provide a flow of 2.8 times the rated current (in RMS value) for a short time, and even four times at peak. Also can provide motor starting current without problem.

<I can show you the behavior of rush current.>

Sine setting of the AC voltage phase is available in the range of 0° to 270° in 90° increment, you can observe the behavior of the rush current flowing to the load while changing the conditions. In addition, my "peak hold" function allows you to observe the highest peak value of the current that flowed at that moment.

<I can provide not only AC output, but also DC.>

Similarly to AC output, setting of voltage value (0 to 424 V) is simple. You can use DC output when testing a DC/DC converter or the like.

<You can achieve capacity increase and three-phase output easily> (applicable to EPO 2000X only).

Just connect EPO 2000X units with an optional system cable, and you can increase the system capacity, and achieve three-phase, single-phase three-wire power supply with ease. Then remove the system cable, and you can retrieve an independent single-phase 2 kVA power supply system. This function releases you from troublesome feeling when you want to change the system frequently.

<I am provided with an interface for computer control.>

Two types are provided for standard: one is GPIB, a standard interface for instrumentation and the other is RS-232, commonly incorporated in personal computers.



Check accessories in package first!

When a package of product reaches you, check for all items first. The package should contain the following accessories:

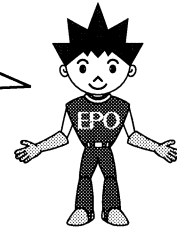

One unit of high-efficiency system power supply, EPO 2000S (or EPO 2000X), main body

Three power cords (3m long 3.5mm² vinyl insulated cables)

One instruction manual for "EPO 2000S/EPO 2000X" (this document)

One flat-blade screwdriver for input/output wiring

If any of the above is missing, contact the company or the dealer.

2

Name of parts

■ In this chapter, I will explain the name of parts and controls of your EPO 2000S/EPO 2000X unit.



Front panel

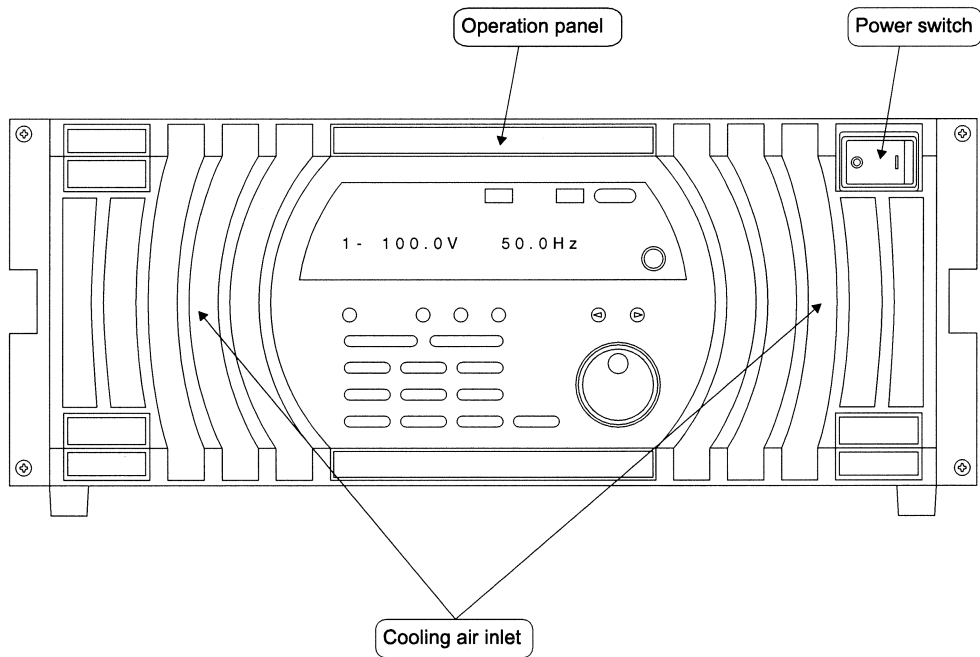

Rear panel

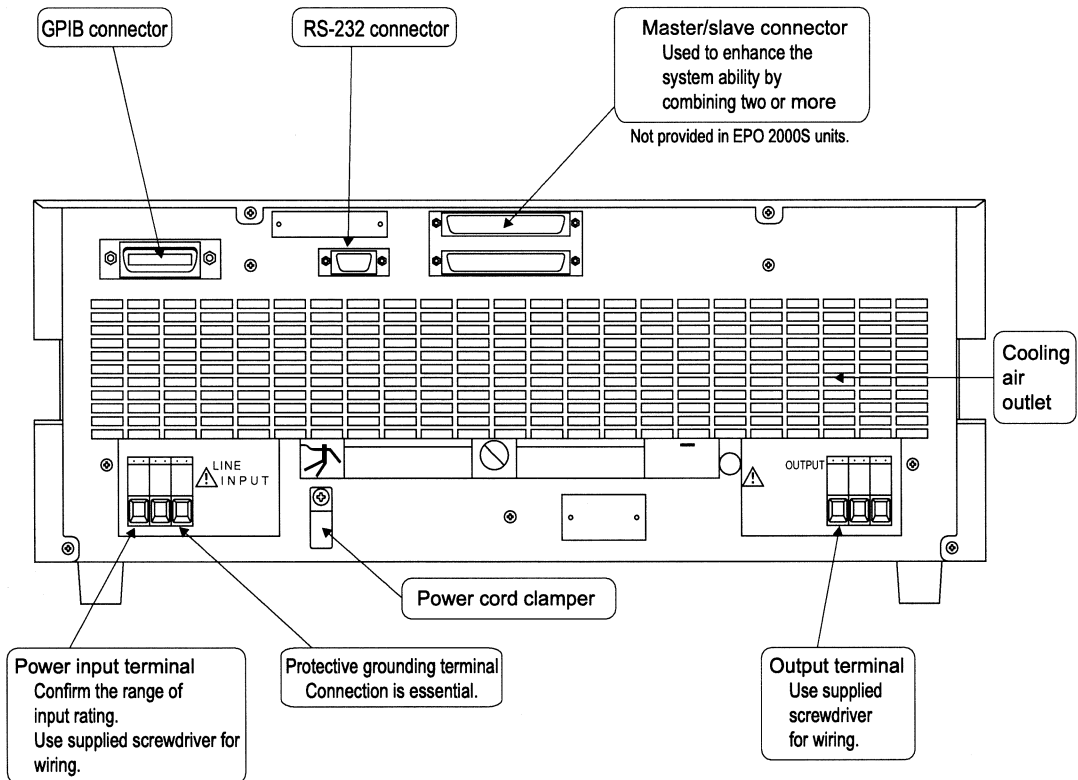

Operation panel

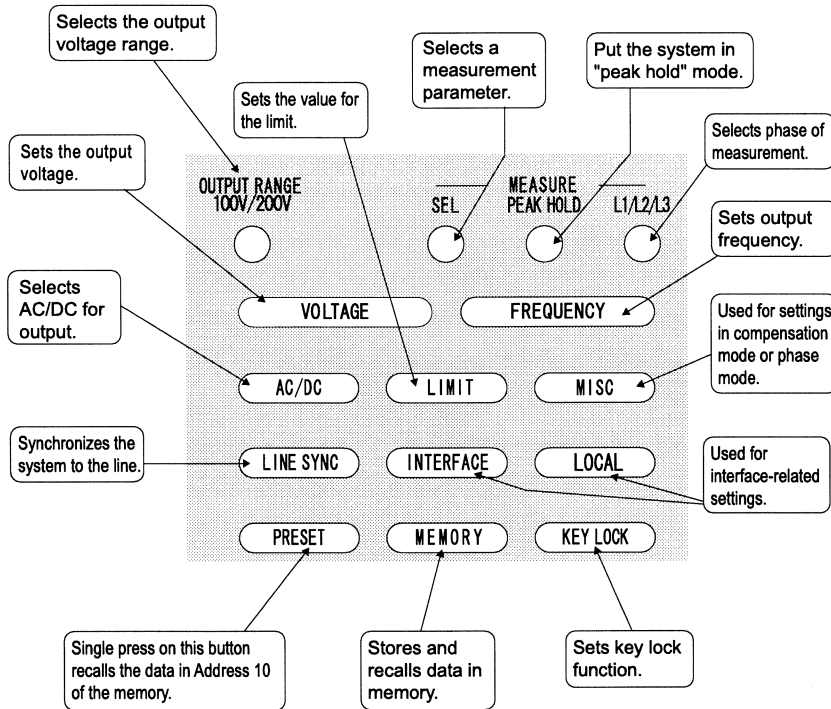
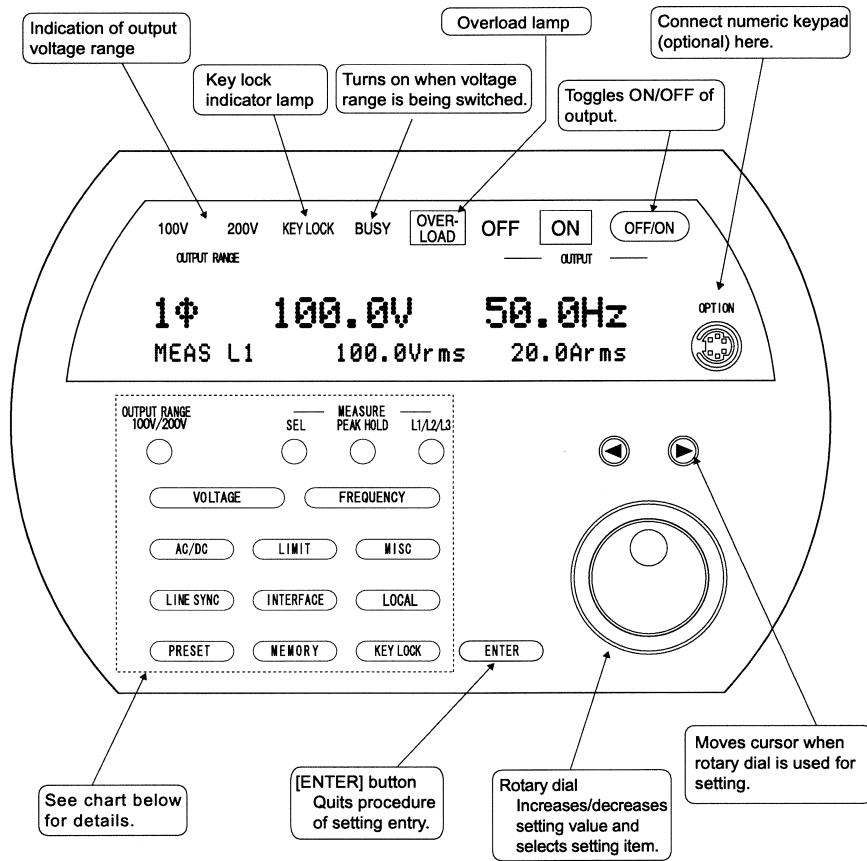

2. Name of parts

3

Installation and Connection

■ This chapter is provided for preparation for starting use of the unit. Please read instructions for installation, and then also read instructions for power connection and different procedures so that the system will be ready for use.

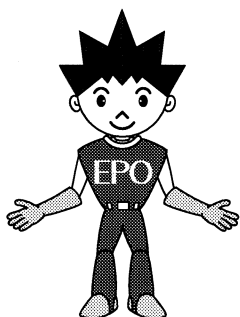



Selection of power supply environment

To ensure safety, use the product in a power supply environment that meets the following conditions:

- Use a power supply that meets the rated range (single-phase AC of 48 to 62 Hz, 170 to 250 V).
- An EPO 2000S/EPO 2000X unit consumes power of about 2.8 kVA. This means, the input current will be approximately 16.5 A at the highest if the power supply voltage is 170 V. Confirm that the planned power supply has a sufficient capacity for the requirement.
- For connection of power supply, use the supplied power cable or another cable that has the same size or thicker diameter.
- Pay ample attention to screw tightening and placement of cables so that the power cable will not be unplugged or loosened accidentally.

● Grounding

Be sure to connect the protective grounding terminal  positively to the electric ground which ground resistance is less than 100 Ω to avoid risk of electric shock.



WARNING

Electric shock will be caused if you touch the chassis that is not connected to the ground because a line filter is used in the power input section.

Be sure to connect the protective grounding terminal before plug in the power cord.



Connection to input and output terminals

Be sure to shut off the power supply on the power switchboard before connection in order to avoid risk of electric shock.

Connection to power input terminal

Use the supplied power cable to place 200 V power supply wiring from the power switchboard to the power input terminal on the rear panel. Indications of L, N and  are marked on the power input terminals. If the power switchboard used is such that one of two conductors is grounded, then connect the grounded pole to the N terminal and the ungrounded pole to the L terminal, respectively. If the power switchboard has a single-phase three-wire structure, then use the 200 V phase between the 1st and 2nd phases for connection instead of using the neutral conductor (or grounding pole). Be sure to connect the protective grounding terminal as well.



WARNING

Be sure to shut off the power supply on the power switchboard before connection in order to avoid risk of electric shock. It is also essential to connect the protective grounding terminal positively.

Connection to output terminal

Output is insulated from the power input.

Both of Hi and Lo of output are insulated from the chassis. Also the Lo terminal can be connected to the chassis for use.



WARNING

Turn off the power to the EPO 2000S/EPO 2000X unit before safe connection of output.



Memo

The internal circuitry of the EPO 2000S/EPO 2000X unit controls the output terminal voltage to be constant at the set voltage. As a result, the load regulation at the load end is affected by the impedance of the wire to the load.

Use a wire with a proper length (not too long unnecessarily) to connect the output terminal to the load and ensure that the terminal connection is made positively without potential loosening. Use an output cable with nominal cross section of at least 3.5mm² or so.

Cable connection to screwed terminal block

This type of terminal accepts a stranded wire of 3.5mm² to 8mm² or a single wire.

Do not carry out any terminal treatment. However, take care so that the tip of the stranded wire will not go through the terminal. The proper tightening torque is 1.8 [N · m] (ca 18 [kgf · cm]).

Procedure of connection

- (1) Strip off 11mm of insulation.
- (2) Use the supplied screwdriver to loosen the screw on the terminal and widen the cable port to the maximum.
- (3) Insert the conductor of the cable.
- (4) Tighten the screw with the driver.

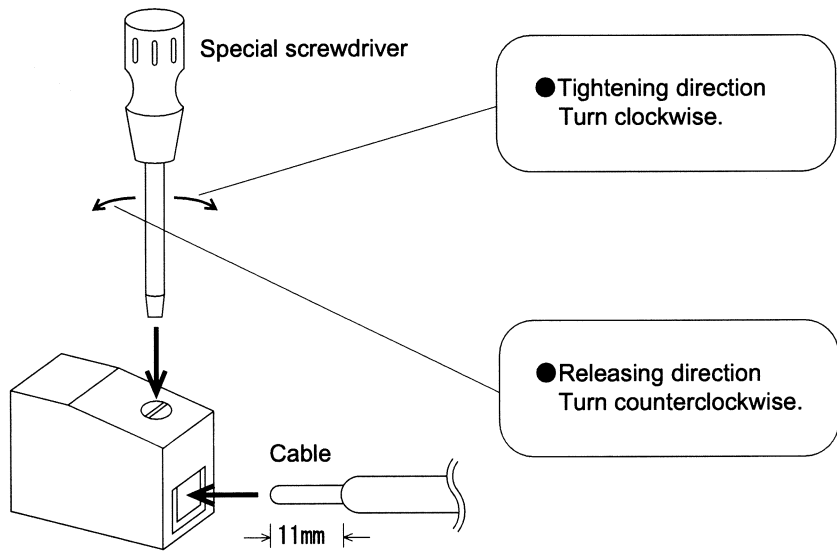

⚠ WARNING

- Be sure to turn off the power before starting connection in order to avoid the risk of electric shock. Note that the metal part of the screw is not isolated from the terminal

⚠ WARNING

- When using a stranded wire, directly insert the copper wire as it is. Carrying out terminal treatment by soldering in particular may cause the contact section to heat abnormally, likely to burn the cable or terminal.

⚠ WARNING

- Insert only one cable to a terminal to avoid a risk. If two or more wires are inserted, they are likely to become loose or come off by a pulling force.

⚠ CAUTION

- Use the supplied screwdriver in wiring operation to ensure positive fastening without damaging the slot of the screw.



Memo

Select a proper cable referring to the table below that shows the relationship between cables and allowable current.

Allowable current for two-core vinyl cabtyre cable

* For VCT cables as per JIS C 3312

(At ambient temperature of 30°C or below)

Nominal cross section [mm ²]	Allowable current [A]
2	22
3.5	32
5.5	42
8	51
14	71
22	95
38	130

(At ambient temperature higher than 30°C)

* Multiply the allowable current value shown in the left table with the reduction factor in the table below

Ambient temperature [°C]	Reduction factor to allowable current
30	1.00
35	0.91
40	0.82
45	0.71
50	0.58

* From JEAC 8001-1986

Relationship between cable length and voltage drop (JIS C 3307 IV cable)

* Use of too long cable causes a voltage drop due to the excessive cable resistance.

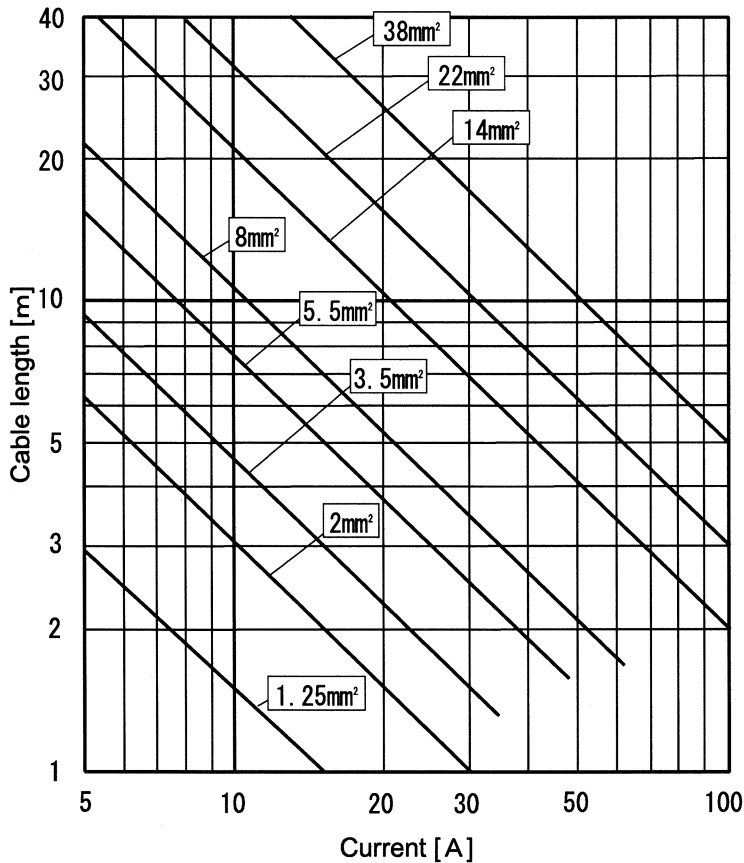

* The diagonal lines indicate the cable length at which voltage drop is 0.5 V due to wiring resistance.

* Values in the rectangle indicate the cross section of the conductor.

Connection of single-phase 2 kVA system

In case of one EPO 2000S/EPO 2000X unit to use, connection should be made as shown in the diagram below:

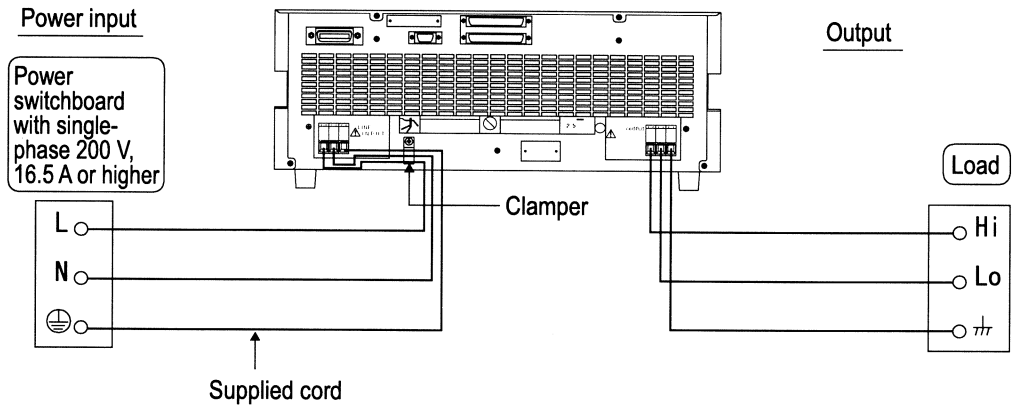

⚠ WARNING

Use clampers in the power input section in particular to fix the cord so that the cord will not be disconnected accidentally, avoiding electric shock and failure.

Connection of single-phase 4 kVA system (use two EPO 2000X units)

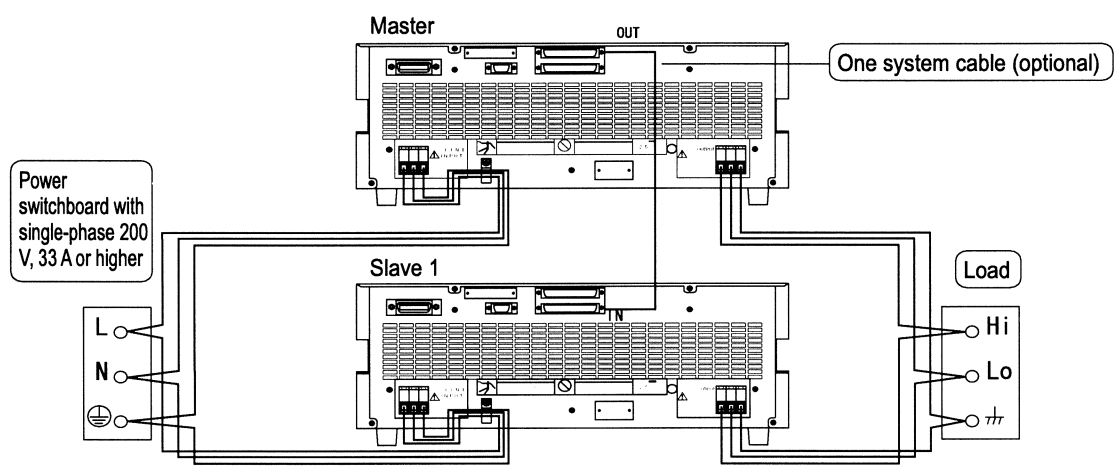

! WARNING

Use claspers in the power input section in particular to fix the cord so that the cord will not be disconnected accidentally, avoiding electric shock and failure.

EPO 2000S/2000X

Connection of single-phase 6 kVA system (use three EPO 2000X units)

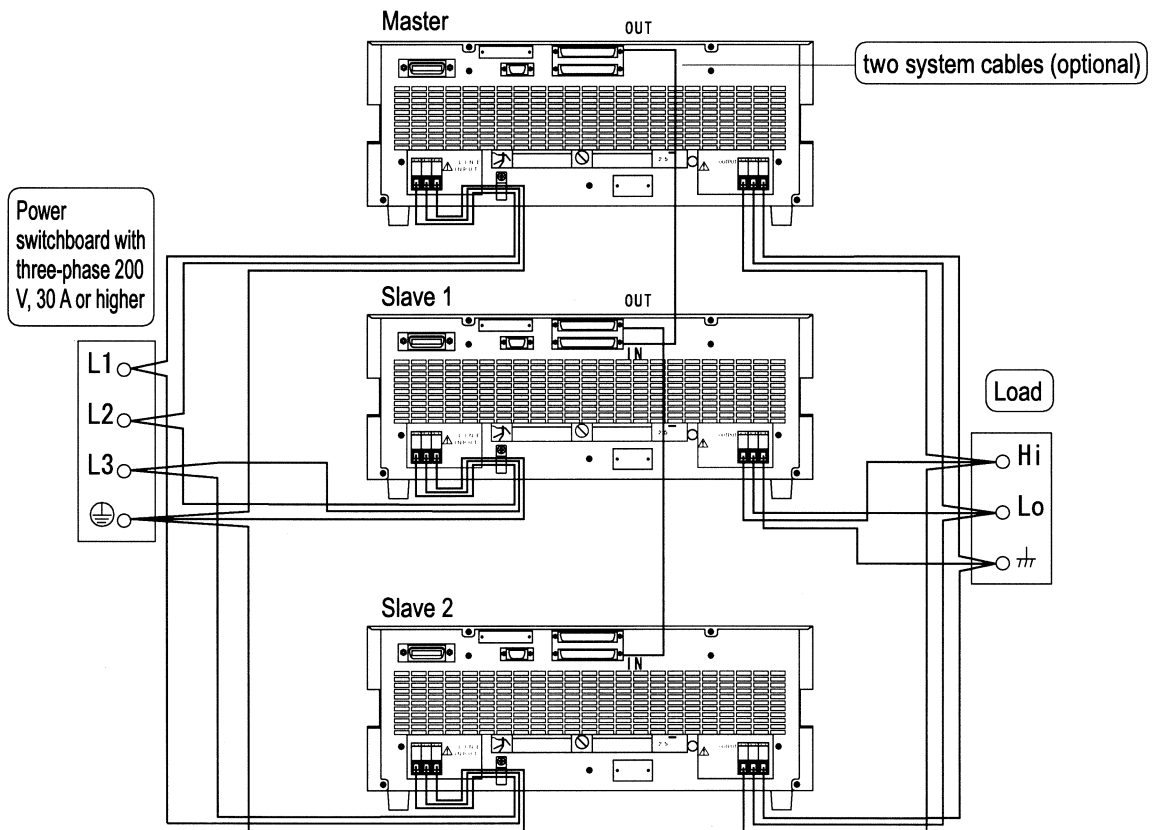

In the case of single-phase power input

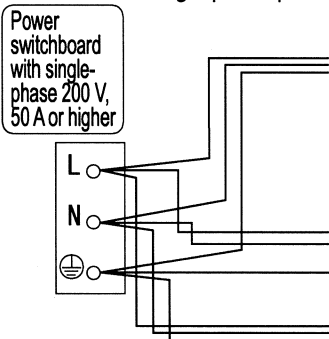

CAUTION

Fix the system cable by tightening the screws on the shield case securely.

Memo

Use of power input unit or output parallel unit for connection
 With a "Power Input Unit" (optional), it is possible to receive a single-phase 200 V power in package and supply the power to a system consisting of up to three units.
 With an "Output Parallel Unit" (optional), it is possible to connect up to three unit outputs in parallel to supply output from a single terminal block.

Connection of three-phase 6 kVA system (use three EPO 2000X units)

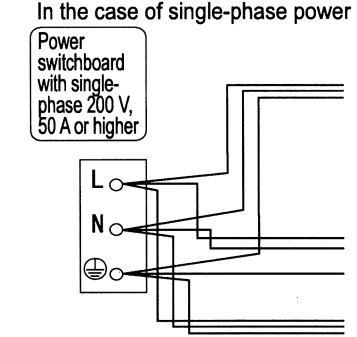
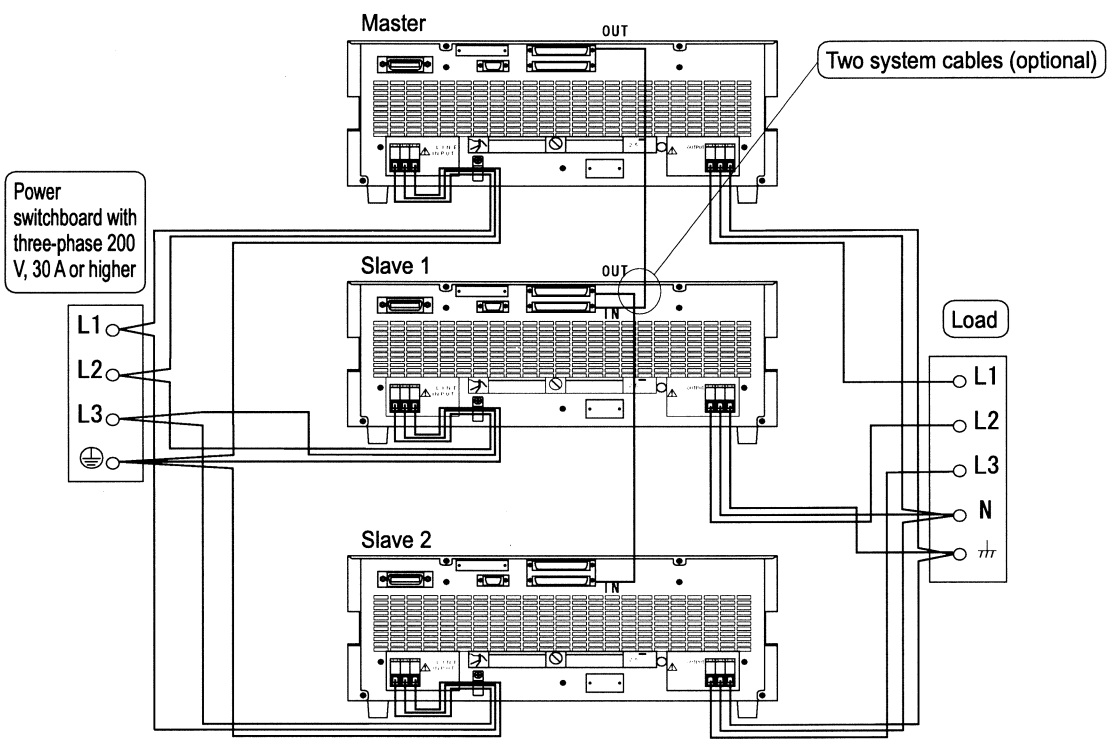

CAUTION

Use star connection for output. Delta connection cannot be used. Be sure to connect Lo terminal of the EPO 2000X output to the neutral point.

Memo

To deal with a three-phase three-wire load, make star connection as shown in the diagram using the terminal block or similar, then connect the load to L1, L2 and L3.

EPO 2000S/2000X

● 3. Installation and Connection ●

Connection of single-phase three-wire 4 kVA system (use two EPO 2000X units)

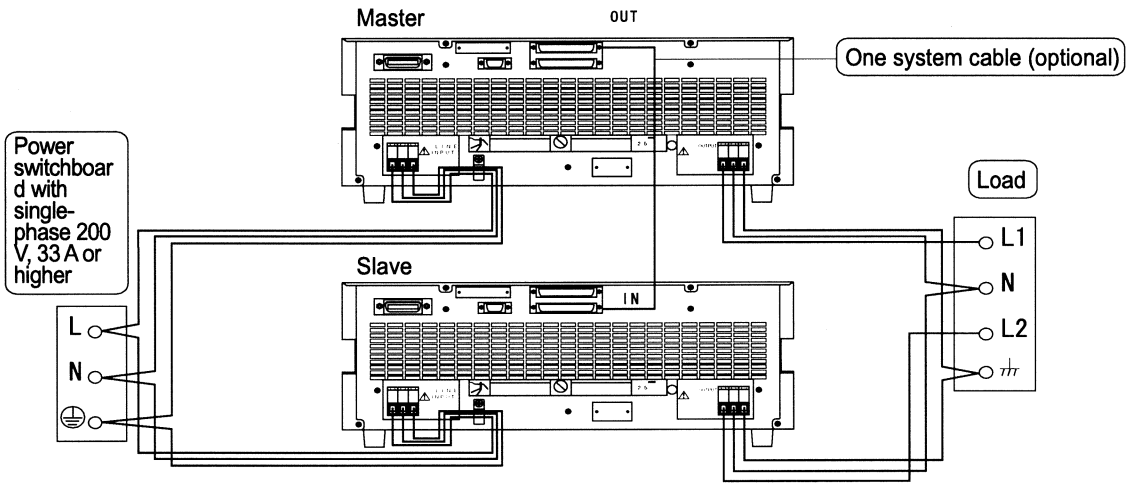

CAUTION

Fix the system cable by tightening the screws on the shield case securely.



Prior to starting operation

Since an EPO 2000S/EPO 2000X unit can provide a voltage of 300 Vac (424 Vdc) at the maximum, wrong operation may cause damage to the connected load or electric shock. Check the following items before starting operation.

(1) If this is the first operation of your unit, connect nothing to the output and you should try rehearsal operation referring to the instruction manual.

(2) Are you sure with the output connection? Confirm that proper cables are used to the maximum current.

(3) Are you sure with the power input connection? Confirm that our specified cables are used.